



EHC – Rulebook - 2006

(replaces all former versions; updated in December 2005)

SUMMARY:

1. EHC – an EHF Sanctioned Competition	page 2
2. Classification	page 2
3. Time Keeping and Ranking	page 3
4. Team ranking	page 4
5. Handbike equipment	page 4
6. Safety	page 5
7. Race	page 6
8. Disciplines, procedures and penalties	page 6
9. Prize money	page 7
10. Event Sponsoring	page 8
11. Exclusion of liability	page 8

1. The EHC – an EHF Sanctioned Competition

- 1.1 The EHC (European Handbike Circuit) is a series of 8 events in 8 different European countries sanctioned by the European Handcycling Federation (EHF).
- 1.2 Applications for sanctioning must be made direct to the EHF Committee by an EHF member nation on behalf of a race organiser.
- 1.3 An event may be a single race or a combination of races within one or two days.
- 1.4 EHC competitions are open for both able-bodied and disabled athletes from all nations.
- 1.3 All participating athletes are subject to the regulations of the EHC.
- 1.4 Race organisers will pay a contribution from the entry fee on behalf of all participants to the EHF. The annual fee for teams is 100 Euros.

2. Classification

- 2.1 Every new member is responsible for their classification and is responsible to get in contact with the relevant EHF representative on this matter. Non-problematic classifications are taken by the EHF representative. The first classification for members is free, but each further classification will be charged 25 Euros.
- 2.2 If a new member fails their first classification, they will be classified in Division C / FC
- 2.3 An athlete may compete in higher classes at any time if desired (see loss of points in conformity with point 3.9)
- 2.4 Every athlete has the right to protest against classification. In this case a majority vote by the EHF Committee will concur the decision, if a protest is accepted or if further checks are demanded. If the same result is repeated the matter is concluded. If it proves otherwise, the EHF Committee reserves the right to demand a third & final check by an IPC classifier.
- 2.5 EHC follows the IPC classification protocol for handcycling. However, it differs in:
- a. number of classes
 - b. admission of able-bodied athletes in Division C / FC
 - c. admission of all disabled athletes who are excluded from handcycling due to IPC eligibility rule N° 3

MEN		
Division	Class	Profile
A	A1	tetraplegics according to T51 in wheelchair racing
	A2	tetraplegics according to T52 in wheelchair racing
B	B	paraplegics from Th1 to Th 9/10
C	C1 Longseat	all other athletes sitting with leg(s) in front
	C2 Kneeseat	all other athletes sitting with bended legs; including double amputees (above-knee amputation)

WOMEN		
Division	Class	Profile
F	FA	tetraplegics
	FB	paraplegics from Th1 to Th 9/10
	FC	all other athletes

2.6 Every athlete of class A2 and B riding using a kneeseat position has to ride in the next class: A2 → B; B → C2

2.7 Every division/class is identifiable by helmet (cover) colour.

A1	blue + yellow 5cm stripe in the middle of the helmet in lengthwise
A2	blue
B	white
C1 / C2	red
FA	green + yellow 5cm stripe ¹ in the middle of the helmet in lengthwise
FB	green + white 5cm stripe ² in the middle of the helmet in lengthwise
FC	green

2.8 Able-bodied athletes have the same rights and obligations as disabled athletes.

3. Time Keeping and Ranking

3.1 The chip for electronic time keeping must be fixed at the left hand side of the front axle & be in a vertical line with the front axle.

3.2 Stage ranking: The ranking is based on the brutto-time of electronic time-keeping measurement which is provided by the event organiser.

3.3 Riders get points for place 1 to 50 according to the table:

place	points	place	points	place	points	place	points	place	points
1	200	11	135	21	97	31	66	41	46
2	185	12	131	22	94	32	64	42	44
3	170	13	128	23	91	33	62	43	42
4	165	14	125	24	88	34	60	44	40
5	160	15	122	25	85	35	58	45	38
6	157	16	119	26	82	36	56	46	36
7	154	17	116	27	79	37	54	47	34
8	152	18	113	28	75	38	52	48	32
9	150	19	110	29	72	39	50	49	30
10	140	20	100	30	69	40	48	50	28

3.4 Overall Ranking: The annual EHC series of races consist of 8 events. An event may be a single race or a combination of multiple races. For every race the full EHC points are available but only the best six results per year will be counted. The rider that accrues the most points is rewarded with the title 'EHC Champion' for that year.

3.5 The present points leader gets the Yellow Jersey at the victory ceremony. During

¹ to get the colour stripe a colour tape may be used too

²

the race he is obliged to wear the yellow helmet cover of the EHC.

- 3.6 The riders wearing the Yellow Jersey are allowed to put their sponsors logos on the jersey.
- 3.7 The points leader only loses the jersey if their next competitor gets more points in the overall ranking.
- 3.8 Rule 3.7. is also valid for the individual ranking list.
- 3.9 Any athlete, who changes from one division to another during the race season for whatever reason, cannot carry their points across. This also applies to athletes who have yet to attain their final decision on classification.

4. Team Ranking

- 4.1 A team is up to a maximum of 10 riders and at least 4 riders shall start in a race in order to attain points. The annual participation fee is 100 Euros per team.
- 4.2 A team can be composed of athletes from different divisions.
- 4.3 Changing of team members is not permitted throughout the year. But uncommitted athletes may join a team until the quota is filled.
- 4.4 Points will be counted from the best four handbikers of a team who finish (max. 800 points). In order to attribute points, all classes will be considered.
- 4.5 Only in the case of a tie of two or more teams the team with the faster accrued time beats the slower one. Ranking will be defined from the total sum of the individual race times of each athlete considered valid about point attribution.
- 4.6 When two or even one rider of a team finish, their points will be counted as well for the team.
- 4.7 As reference to point 3.4, the best 6 results are counted.
- 4.8 A team shall be recognised by identical race-suits.

5. Handbike-equipment

- 5.1 EHC-rule on handbike-equipment corresponds to IPC/UCI regulations (15.006; 18.001 – 18.009) except points 5.2, 5.3, 5.4 and 5.5 given below. Only **three** wheeled bikes solely propelled by arm / trunk power are permitted for ranking. As of 2006 **two** wheeled bikes solely propelled by arm / trunk power are permitted only for demo purpose – without ranking and awards.
- 5.2 Exception – no backrest angle rule (angle of 45°): Every athlete should have the capacity to optimise their position for their functionality. Safe riding **and all-round vision** lies with the athletes responsibility. The rider shall be held responsible for damages or injuries against himself or third-party.

5.3 Exception – safety bar: All handcycles with two rear wheels must be fitted with a safety bar except for time trials.

SKIZZE:

Abstandhalter

(nicht maßstabgetreu)

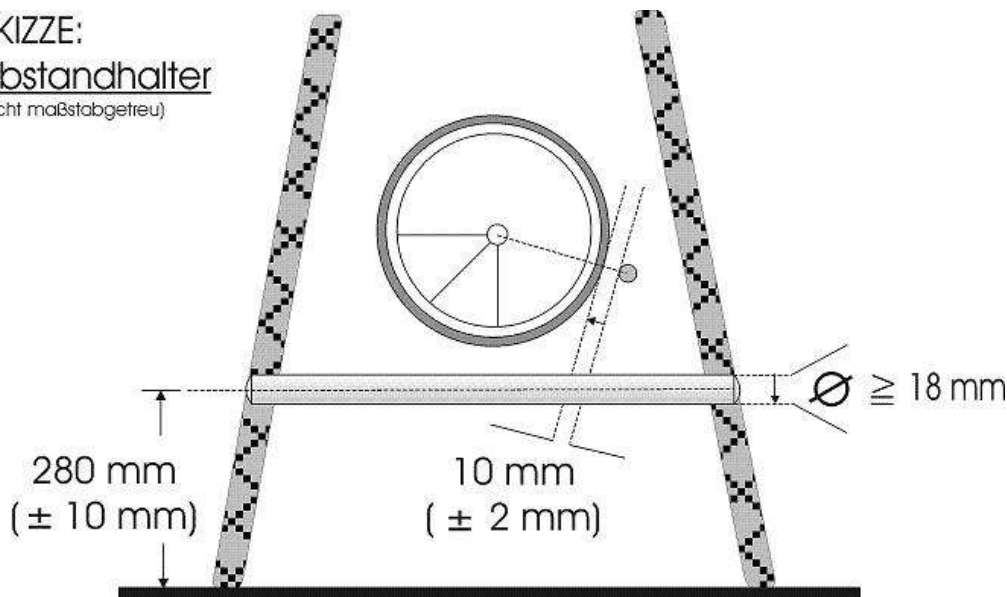

5.3.1 Definition and assembly instructions for the safety bar:

5.3.2 The safety bar must be a round tube (at least 18 mm diameter) made of adequate solid material. Both tube ends must be plugged.

5.3.3 The distance between ground and bar axis must be 280 mm (+/- 10 mm)

5.3.4 The safety bar must not exceed the width of each rear wheel tyre.

5.3.5 The safety bar must be fitted 10 mm (+/- 2 mm) behind the tyre.

5.3.6 The structure and assembly of the safety bar must guarantee that normal bumps, which happen during a race, don't impact the safe function of the bar.

5.4 Exception – spoke covers /disk wheels: it is recommended to fit spoke covers outside and inside of wheels or to use disk wheels. (Notice: from 2006 trispokes and fourspokes will be banned in road races)

5.5 The width of handcycle double wheels may vary between 85 cm maximum and 60 cm minimum. Exception - in the case of body lean steering the minimum width can be 40cm minimum

6. Safety

6.1 In road races, the wearing of a rigid safety helmet, to international UCI standard for cycle racing, is compulsory for all athletes.

6.2 Aerodynamic time-trial helmets are only permitted in time-trials.

- 6.3** Race approval of a handcycle may be denied, if certain parts on an athletes handcycle could potentially endanger the rider or their competitors.
- 6.4** If a handcycle is damaged during the race & potentially doesn't fulfil equipment regulations
- a. the athlete is obliged to stop to repair their equipment or to withdraw.
 - b. the organiser is entitled to stop the athlete for repair or to withdraw them from the race.

7. Race

- 7.1.** Starting order depends on the EHC overall ranking list until place 10. The riders are obliged to be present at the starting line 10 minutes before, otherwise they have to start at the end of the division.
- 7.2.** Between each division start (C (mixed) – B – A (mixed) - F (mixed)) there has to be a break of at least one minute. It is also possible to organise a separate race for each division.
- 7.3.** It is forbidden to draft behind athletes from another division or behind athletes from another category (wheelchair racers, inline skaters etc)
- 7.4.** To prevent distortion of results, it is forbidden to draft a rider who is overtaking and lapping.

8. Discipline, procedures and penalties

- 8.1** Every member of the EHC is obliged to follow the EHC rules and agrees to the decisions and judgements of the EHC.
- 8.2** Statements made by referees in reports and minutes shall be deemed probatory unless proven otherwise.
- 8.3** Anyone who behaves in an incorrect or dishonest fashion with regard to any other or fails to meet the obligations of EHC regulations may be penalised by
- a. Referee Panel from the EHF representatives in point 1.
 - b. EHF Committee in last instance. Any member of the EHF Committee who might be involved in a disciplinary issue (rider), cannot influence the decision by their vote.
- 8.4** The main official in an EHC race is the Chief Referee. He and at least two Judges form the Referee Panel.
- 8.5** A written protest has to be submitted to the Referee Panel within 30 minutes after the race concludes. The protest fee is 50 Euros. When the protest is honoured the fee will be refunded.
- 8.6** The offending party has the chance to defend his point of view within 30 minutes after the protest has been submitted. If the athlete doesn't adequately justify their actions they can be judged in absence too. Teamleaders and/or athletes have to take care to be present at the Panel desk and to get information about potential protests.

8.7. The offending party has the right to protest against a decision according to point 8.3a. The protest fee is 50 Euros. When the protest is honoured the fee will be refunded.

8.8 The scale of penalties increase from warning, point-reduction, time-penalty, disqualification up to exclusion.

8.9 Rules concerning specific race incidents and the scale of penalties are listed below (some following UCI rules):

offences	penalties
a To start with handcycle which is not in conformity with the regulations	start refused
b Using a handcycle in race which is not in conformity with the regulations	stopping according to rule 6.4b
c Rider taking the start without required helmet	start refused
d Rider removing helmet during the race	warning up to disqualification
e Rider failing to respect the starting order according to ranking list	reduction of 20 points ³
f forbidden drafting according to point 7.3	10 minutes time penalty or disqualification in case of recurrence
g infringement of rule 7.4	10 minutes time penalty
h Wilful obstruction of a rider belonging to another division	disqualification of obstructing rider
i Irregular sprint at finish (deviating from selected lane, endangering other riders)	relegation to last place of sprinting group or reduction of 20 points or relegation to end of stage ranking
j Pushing aside or endangering another rider in race	reduction of 20 points or relegation to end of stage ranking
k Irregular pushing constituting an advantage	see point i
l Making shortcuts on the circuit	disqualification
m Fraud or attempted fraud	disqualification up to exclusion for one year
n Insults, threats, unseemly behaviour towards riders and others	time penalty up to elimination
o non-participation at victory ceremony	losing prize for benefit of EHC
p Absence at prize ceremony for Yellow Jersey without reason ⁴	reduction of 20 points
q Ignoring 10m / 1m distance in time trial for short distance	time penalty: 30 seconds per offence
r Ignoring 10m / 1m distance in time trial for long distance	time penalty: 5 minutes

9. Prize money

9.1 The prize money for the winner will not be distributed unless at least 3 athletes participated in the race.

The prize money for the best 2 athletes will not be distributed unless at least 4 athletes participated in the race.

The prize money for the best 3 athletes will not be distributed unless at

³if start is neutralized the starting order must be held until release of race too

⁴if your absence is unavoidable please contact your country representative in time

least 5 athletes participated in the race.

9.2 At the end of the EHC series, the EHF Committee will distribute prize money for the best places in the overall ranking.

9.4 According to rule 8.9.o non-participation at the victory ceremony will cause loss of prize money for the benefit of EHF.

10. Event Sponsoring

10.1 Interested companies will get information and a sponsor listing on demand.

11. Exclusion of liability

11.1 With your participation to one or more races and additional events of the EHC, you acknowledge the liability-exclusion of the EHF-Committee or of involved third-party for personal or material damage.

EHF Committee
December 2005